

LMP8601/LMP8601Q

60V Common Mode, Bidirectional Precision Current Sensing Amplifier

General Description

The LMP8601 and LMP8601Q are fixed 20x gain precision amplifiers. The part will amplify and filter small differential signals in the presence of high common mode voltages. The input common mode voltage range is -22V to +60V when operating from a single 5V supply. With 3.3V supply, the input common mode voltage range is from -4V to +27V. The LMP8601 and LMP8601Q are members of the Linear Monolithic Precision (LMP®) family and are ideal parts for unidirectional and bidirectional current sensing applications. All parameter values of the part that are shown in the tables are 100% tested and all bold values are also 100% tested over temperature.

The part has a precise gain of 20x which is adequate in most targeted applications to drive an ADC to its full scale value. The fixed gain is achieved in two separate stages, a preamplifier with a gain of 10x and an output stage buffer amplifier with a gain of 2x. The connection between the two stages of the signal path is brought out on two pins to enable the possibility to create an additional filter network around the output buffer amplifier. These pins can also be used for alternative configurations with different gain as described in the applications section .

The mid-rail offset adjustment pin enables the user to use these devices for bidirectional single supply voltage current sensing. The output signal is bidirectional and mid-rail referenced when this pin is connected to the positive supply rail. With the offset pin connected to ground, the output signal is unidirectional and ground-referenced .

The LMP8601Q incorporates enhanced manufacturing and support processes for the automotive market, including defect detection methodologies. Reliability qualification is compliant with the requirements and temperature grades defined in the AEC Q100 standard.

Features

Unless otherwise noted, typical values at $T_A = 25^\circ\text{C}$, $V_S = 5.0\text{V}$, Gain = 20x

- TCV_{OS} 10 $\mu\text{V}/^\circ\text{C}$ max
- CMRR 90 dB min
- Input offset voltage 1 mV max
- CMVR at $V_S = 3.3\text{V}$ -4V to 27V
- CMVR at $V_S = 5.0\text{V}$ -22V to 60V
- Operating ambient temperature range -40 $^\circ\text{C}$ to 125 $^\circ\text{C}$
- LMP8601Q available in Automotive AEC-Q100 Grade 1 qualified version
- Single supply bidirectional operation
- All Min / Max limits 100% tested

Applications

- High side and low side driver configuration current sensing
- Bidirectional current measurement
- Current loop to voltage conversion
- Automotive fuel injection control
- Transmission control
- Power steering
- Battery management systems

Typical Applications

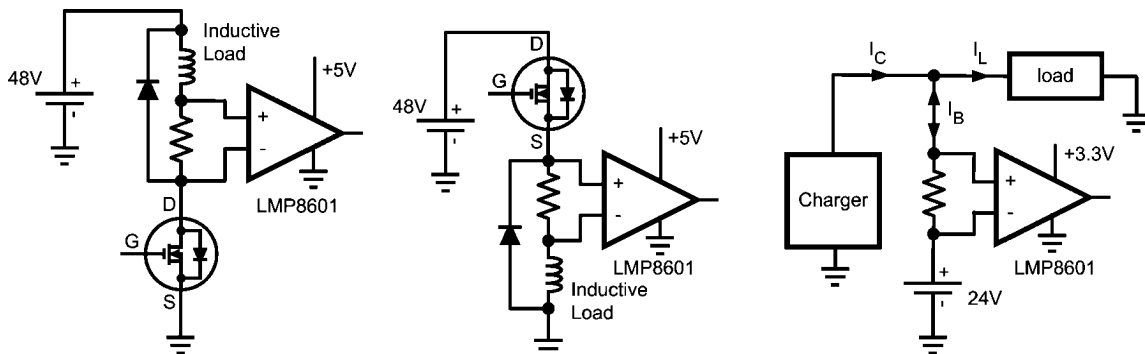

20157101

Absolute Maximum Ratings (Note 1)

If Military/Aerospace specified devices are required, please contact the National Semiconductor Sales Office/ Distributors for availability and specifications.

ESD Tolerance (Note 4)	
Human Body	
For input pins only	±4000V
For all other pins	±2000V
Machine Model	200V
Charge Device Model	1000V
Supply Voltage (V_S - GND)	6.0V
Continuous Input Voltage (Pin 1 and Pin 8)	-22V to 60V
Transient (400 ms)	-25V to 65V

Storage Temperature Range	-65°C to 150°C
Junction Temperature (Note 3)	150°C
Mounting Temperature	
Infrared or Convection (20 sec)	235°C
Wave Soldering Lead (10 sec)	260°C

Operating Ratings (Note 1)

Supply Voltage (V_S - GND)	3.0V to 5.5V
Offset Voltage (Pin 7)	0 to V_S
Temperature Range (Note 3)	
Packaged devices	-40°C to +125°C
Package Thermal Resistance (Note 3)	
8-Pin SOIC (θ_{JA})	190°C/W

3.3V Electrical Characteristics (Note 2)

Unless otherwise specified, all limits guaranteed at $T_A = 25^\circ\text{C}$, $V_S = 3.3\text{V}$, $\text{GND} = 0\text{V}$, $-4\text{V} \leq V_{\text{CM}} \leq 27\text{V}$, and $R_L = \infty$, Offset (Pin 7) is grounded, 10nF between V_S and GND. **Boldface** limits apply at the temperature extremes.

Symbol	Parameter	Conditions	Min (Note 6)	Typ (Note 5)	Max (Note 6)	Units	
Overall Performance (From -IN (pin 1) and +IN (pin 8) to OUT (pin 5) with pins A1 (pin 3) and A2 (pin 4) connected)							
I_S	Supply Current		0.6	1	1.3	mA	
A_V	Total Gain		19.9	20	20.1	V/V	
	Gain Drift (Note 14)	$-40^\circ\text{C} \leq T_A \leq 125^\circ\text{C}$		-2.7	±20	ppm/°C	
SR	Slew Rate (Note 7)	$V_{\text{IN}} = \pm 0.165\text{V}$	0.4	0.7		V/ μs	
BW	Bandwidth		50	60		kHz	
V_{OS}	Input Offset Voltage	$V_{\text{CM}} = V_S / 2$		0.15	±1	mV	
TCV_{OS}	Input Offset Voltage Drift (Note 8)	$-40^\circ\text{C} \leq T_A \leq 125^\circ\text{C}$		2	±10	$\mu\text{V}/^\circ\text{C}$	
e_n	Input Referred Voltage Noise	0.1 Hz – 10 Hz, 6 Sigma		16.4		$\mu\text{V}_{\text{P-P}}$	
		Spectral Density, 1 kHz		830		nV/ $\sqrt{\text{Hz}}$	
PSRR	Power Supply Rejection Ratio	DC, $3.0\text{V} \leq V_S \leq 3.6\text{V}$, $V_{\text{CM}} = V_S/2$	70	86		dB	
	Mid-scale Offset Scaling Accuracy			±0.15	±0.5	%	
Preamplifier (From input pins -IN (pin 1) and +IN (pin 8) to A1 (pin 3))							
R_{CM}	Input Impedance Common Mode	$-4\text{V} \leq V_{\text{CM}} \leq 27\text{V}$	250	295	350	k Ω	
R_{DM}	Input Impedance Differential Mode	$-4\text{V} \leq V_{\text{CM}} \leq 27\text{V}$	500	590	700	k Ω	
V_{OS}	Input Offset Voltage	$V_{\text{CM}} = V_S / 2$		±0.15	±1	mV	
DC CMRR	DC Common Mode Rejection Ratio	$-2\text{V} \leq V_{\text{CM}} \leq 24\text{V}$	86	96		dB	
AC CMRR	AC Common Mode Rejection Ratio (Note 9)	f = 1 kHz	80	94		dB	
		f = 10 kHz		85			
CMVR	Input Common Mode Voltage Range	for 80 dB CMRR	-4		27	V	
A_{1V}	Gain (Note 14)		9.95	10.0	10.05	V/V	
$R_{\text{F-INT}}$	Output Impedance Filter Resistor		99	100	101	k Ω	
$\text{TCR}_{\text{F-INT}}$	Output Impedance Filter Resistor Drift			±5	±50	ppm/°C	
$A1 V_{\text{OUT}}$	A1 Output Voltage Swing	V_{OL}	$R_L = \infty$		2	10	mV
		V_{OH}		3.2	3.25		V

Symbol	Parameter	Conditions	Min (Note 6)	Typ (Note 5)	Max (Note 6)	Units	
Output Buffer (From A2 (pin 4) to OUT(pin 5))							
V_{OS}	Input Offset Voltage	$0V \leq V_{CM} \leq V_S$	-2 -2.5	± 0.5	2 2.5	mV	
A_{2V}	Gain (Note 14)		1.99	2	2.01	V/V	
I_B	Input Bias Current of A2 (Note 10),			-40		fA	
					± 20	nA	
$A_2 V_{OUT}$	A2 Output Voltage Swing (Notes 11, 12)	V_{OL}	$R_L = 100 \text{ k}\Omega$		4	20	mV
		V_{OH}		3.28	3.29		V
I_{SC}	Output Short-Circuit Current (Note 13)	Sourcing, $V_{IN} = V_S$, $V_{OUT} = \text{GND}$	-25	-38	-60	mA	
		Sinking, $V_{IN} = \text{GND}$, $V_{OUT} = V_S$	30	46	65		

5V Electrical Characteristics (Note 2)

Unless otherwise specified, all limits guaranteed for at $T_A = 25^\circ\text{C}$, $V_S = 5\text{V}$, $\text{GND} = 0\text{V}$, $-22\text{V} \leq V_{CM} \leq 60\text{V}$, and $R_L = \infty$, Offset (Pin 7) is grounded, 10nF between V_S and GND. **Boldface** limits apply at the temperature extremes.

Symbol	Parameter	Conditions	Min (Note 6)	Typ (Note 5)	Max (Note 6)	Units	
Overall Performance (From -IN (pin 1) and +IN (pin 8) IN to OUT (pin 5) with pins A1 (pin 3) and A2 (pin 4) connected)							
I_S	Supply Current		0.7	1.1	1.5	mA	
A_V	Total Gain (Note 14)		19.9	20	20.1	V/V	
	Gain Drift	$-40^\circ\text{C} \leq T_A \leq 125^\circ\text{C}$		-2.8	± 20	ppm/ $^\circ\text{C}$	
SR	Slew Rate (Note 7)	$V_{IN} = \pm 0.25\text{V}$	0.6	0.83		V/ μs	
BW	Bandwidth		50	60		kHz	
V_{OS}	Input Offset Voltage			0.15	± 1	mV	
TCV_{OS}	Input Offset Voltage Drift (Note 8)	$-40^\circ\text{C} \leq T_A \leq 125^\circ\text{C}$		2	± 10	$\mu\text{V}/^\circ\text{C}$	
e_N	Input Referred Voltage Noise	0.1 Hz – 10 Hz, 6 Sigma		17.5		μV_{P-P}	
		Spectral Density, 1 kHz		890		nV/ $\sqrt{\text{Hz}}$	
PSRR	Power Supply Rejection Ratio	$\text{DC } 4.5\text{V} \leq V_S \leq 5.5\text{V}$	70	90		dB	
	Mid-scale Offset Scaling Accuracy			± 0.15	± 0.5	%	
Preamplifier (From input pins -IN (pin 1) and +IN (pin 8) to A1 (pin 3))							
R_{CM}	Input Impedance Common Mode	$0\text{V} \leq V_{CM} \leq 60\text{V}$	250	295	350	k Ω	
		$-20\text{V} \leq V_{CM} \leq 0\text{V}$	165	193	250	k Ω	
R_{DM}	Input Impedance Differential Mode	$0\text{V} \leq V_{CM} \leq 60\text{V}$	500	590	700	k Ω	
		$-20\text{V} \leq V_{CM} \leq 0\text{V}$	300	386	500	k Ω	
V_{OS}	Input Offset Voltage	$V_{CM} = V_S / 2$		± 0.15	± 1	mV	
DC CMRR	DC Common Mode Rejection Ratio	$-20\text{V} \leq V_{CM} \leq 60\text{V}$	90	105		dB	
AC CMRR	AC Common Mode Rejection Ratio (Note 9)	$f = 1 \text{ kHz}$	80	96		dB	
		$f = 10 \text{ kHz}$		83			
CMVR	Input Common Mode Voltage Range	for 80 dB CMRR	-22		60	V	
A_{1V}	Gain (Note 14)		9.95	10	10.05	V/V	
R_{F-INT}	Output Impedance Filter Resistor		99	100	101	k Ω	
TCR_{F-INT}	Output Impedance Filter Resistor Drift			± 5	± 50	ppm/ $^\circ\text{C}$	
$A_1 V_{OUT}$	A1 Output Voltage Swing	V_{OL}	$R_L = \infty$		2	10	mV
		V_{OH}		4.95	4.985		V
Output Buffer (From A2 (pin 4) to OUT(pin 5))							
V_{OS}	Input Offset Voltage	$0\text{V} \leq V_{CM} \leq V_S$	-2 -2.5	± 0.5	2 2.5	mV	
A_{2V}	Gain (Note 14)		1.99	2	2.01	V/V	

Symbol	Parameter	Conditions	Min (Note 6)	Typ (Note 5)	Max (Note 6)	Units
I_B	Input Bias Current of A2 (Note 10)			-40		fA
					± 20	nA
A2 V_{OUT}	A2 Output Voltage Swing (Notes 11, 12)	V_{OL}	$R_L = 100\text{ k}\Omega$	4	20	mV
		V_{OH}		4.98		4.99
I_{SC}	Output Short-Circuit Current (Note 13)	Sourcing, $V_{IN} = V_S$, $V_{OUT} = \text{GND}$	-25	-42	-60	mA
		Sinking, $V_{IN} = \text{GND}$, $V_{OUT} = V_S$	30	48	65	

Note 1: "Absolute Maximum Ratings" indicate limits beyond which damage to the device may occur, including inoperability and degradation of the device reliability and/or performance. Functional operation of the device and/or non-degradation at the Absolute Maximum Ratings or other conditions beyond those indicated in the Recommended Operating Conditions is not implied. The Recommended Operating Conditions indicate conditions at which the device is functional and the device should not be beyond such conditions. All voltages are measured with respect to the ground pin, unless otherwise specified.

Note 2: The electrical Characteristics tables list guaranteed specifications under the listed Recommended Operating Conditions except as otherwise modified or specified by the Electrical Characteristics Conditions and/or Notes. Typical specifications are estimations only and are not guaranteed.

Note 3: The maximum power dissipation must be derated at elevated temperatures and is dictated by $T_{J(MAX)}$, θ_{JA} , and the ambient temperature, T_A . The maximum allowable power dissipation $P_{DMAX} = (T_{J(MAX)} - T_A) / \theta_{JA}$ or the number given in Absolute Maximum Ratings, whichever is lower.

Note 4: Human Body Model per MIL-STD-883, Method 3015.7. Machine Model, per JESD22-A115-A. Field-Induced Charge-Device Model, per JESD22-C101-C.

Note 5: Typical values represent the most likely parameter norms at $T_A = +25^\circ\text{C}$, and at the Recommended Operation Conditions at the time of product characterization and are not guaranteed.

Note 6: Datasheet min/max specification limits are guaranteed by test.

Note 7: Slew rate is the average of the rising and falling slew rates.

Note 8: Offset voltage drift determined by dividing the change in V_{OS} at temperature extremes into the total temperature change.

Note 9: AC Common Mode Signal is a $5V_{PP}$ sine-wave (0V to 5V) at the given frequency.

Note 10: Positive current corresponds to current flowing into the device

Note 11: For this test input is driven from A1 stage.

Note 12: For V_{OL} , R_L is connected to V_S and for V_{OH} , R_L is connected to GND.

Note 13: Short-Circuit test is a momentary test. Continuous short circuit operation at elevated ambient temperature can result in exceeding the maximum allowed junction temperature of 150°C

Note 14: Both the gain of the preamplifier A_{1V} and the gain of the buffer amplifier A_{2V} are measured individually. The over all gain of both amplifiers A_V is also measured to assure the gain of all parts is always within the A_V limits

Block Diagram

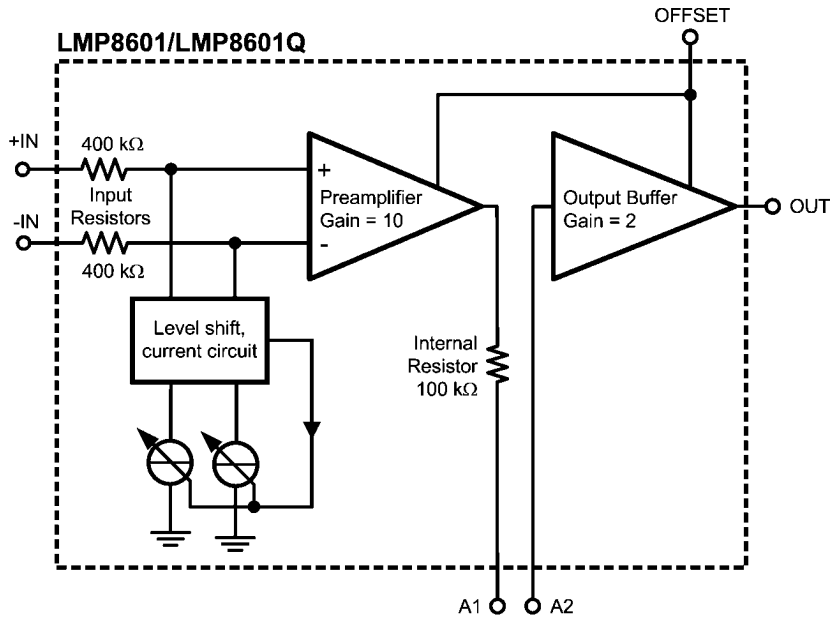

20157105

Connection Diagram

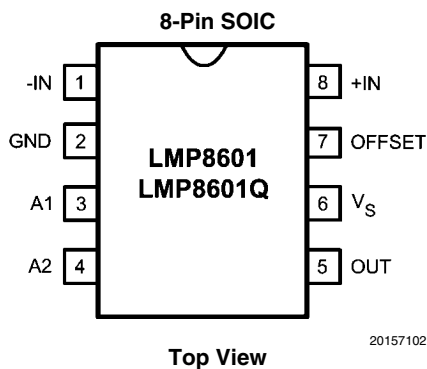

Pin Descriptions

	Pin	Name	Description
Power Supply	2	GND	Power Ground
	6	V _S	Positive Supply Voltage
Inputs	1	-IN	Negative Input
	8	+IN	Positive Input
Filter Network	3	A1	Preamplifier output
	4	A2	Input from the external filter network and / or A1
Offset	7	OFFSET	DC Offset for bidirectional signals
Output	5	OUT	Single ended output

Ordering Information

Package	Part Number	Package Marking	Transport Media	NSC Drawing
8-Pin SOIC	LMP8601MA	LMP8601MA	95 Units/Rail	M08A
	LMP8601MAX		2.5K Units Tape and Reel	
	LMP8601QMA	LMP8601QMA	95 Units/Rail	
	LMP8601QMAX		2.5K Units Tape and Reel	

Automotive Grade (Q) product incorporates enhanced manufacturing and support processes for the automotive market, including defect detection methodologies. Reliability qualification is compliant with the requirements and temperature grades defined in the AEC Q100 standard. Automotive Grade products are identified with the letter Q. Fully compliant PPAP documentation is available. For more information go to <http://www.national.com/automotive>.

Typical Performance Characteristics

Unless otherwise specified, all limits guaranteed for at $T_A = 25^\circ\text{C}$, $V_S = 5\text{V}$, $\text{GND} = 0\text{V}$, $-22 \leq V_{\text{CM}} \leq 60\text{V}$, and $R_L = \infty$, Offset (Pin 7) connected to V_S , 10nF between V_S and GND.

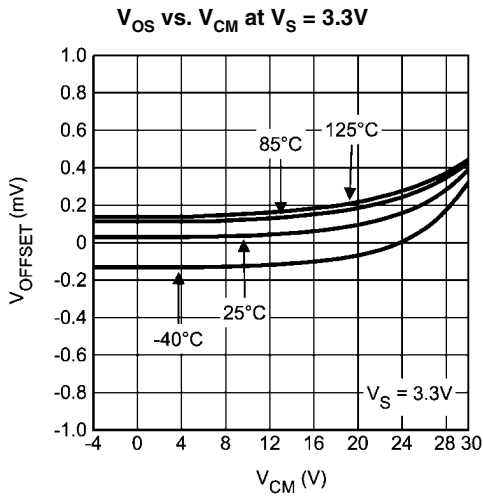

20157124

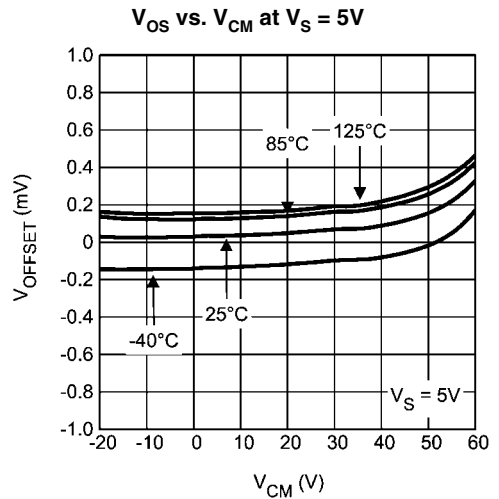

20157125

Input Bias Current Over Temperature (A1 Inputs) at $V_S = 3.3\text{V}$

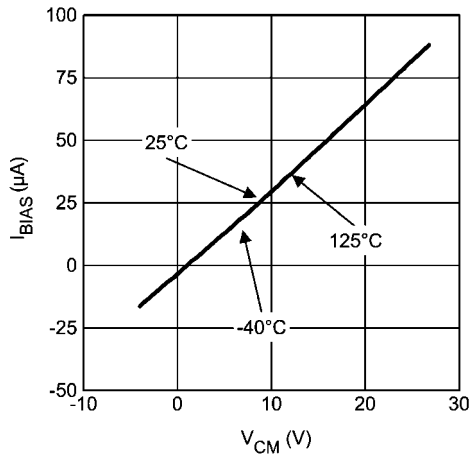

20157141

Input Bias Current Over Temperature (A1 Inputs) at $V_S = 5\text{V}$

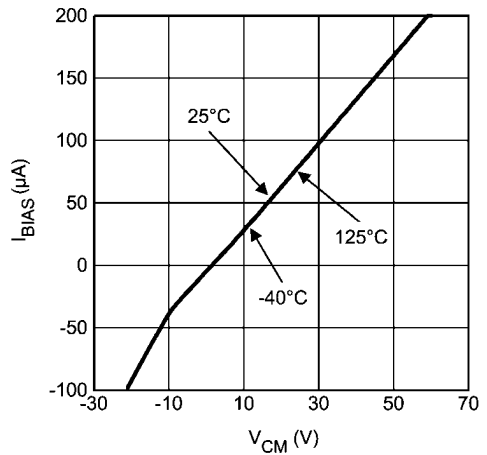

20157142

Input Bias Current Over Temperature (A2 Inputs) at $V_S = 5\text{V}$

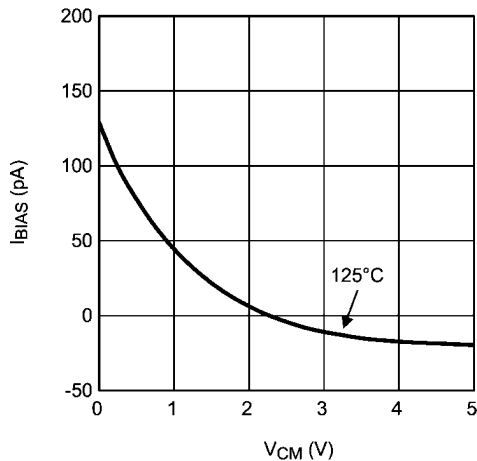

20157127

Input Bias Current Over Temperature (A2 Inputs) at $V_S = 5\text{V}$

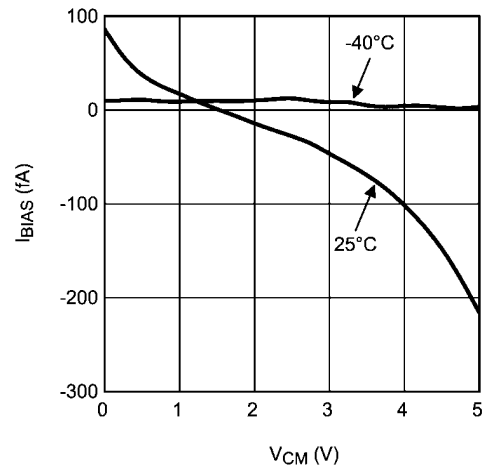

20157126

Input Referred Voltage Noise vs. Frequency

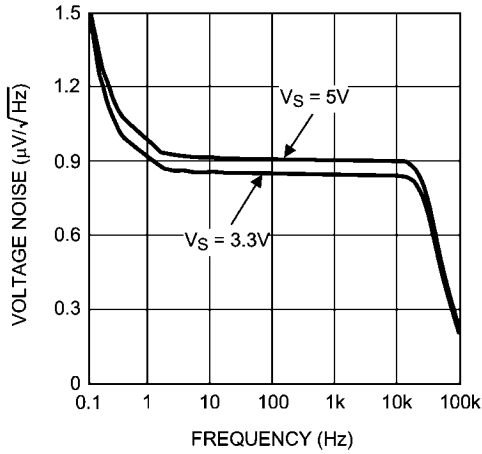

20157110

PSRR vs. Frequency

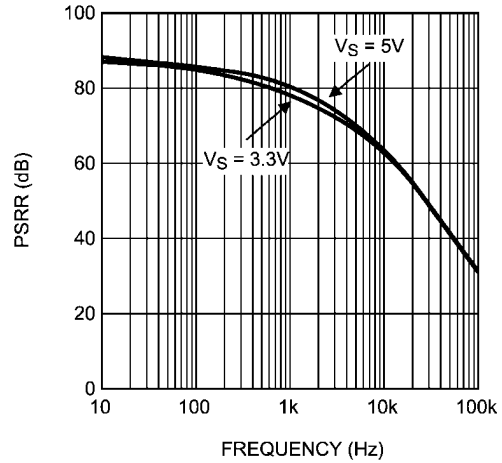

20157117

Gain vs. Frequency at VS = 3.3V

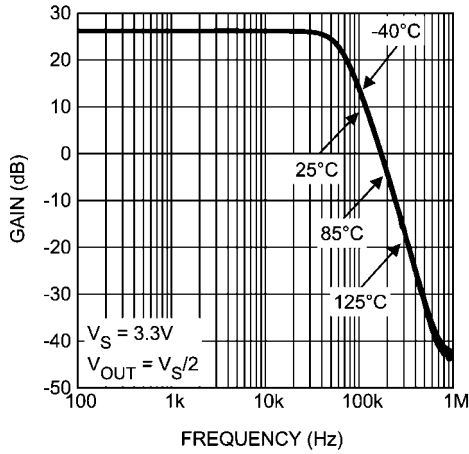

20157111

Gain vs. Frequency at VS = 5V

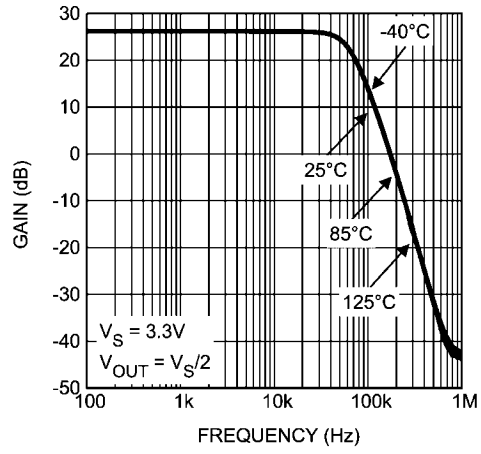

20157112

CMRR vs. Frequency at VS = 3.3V

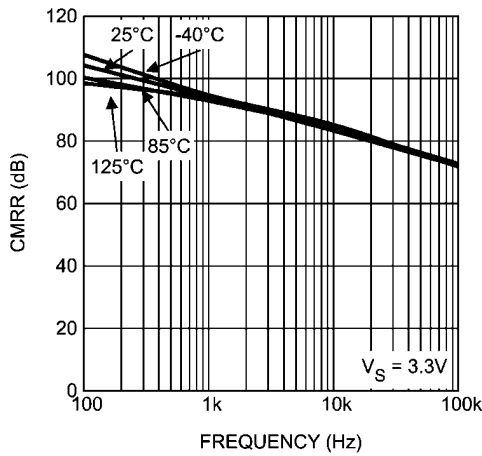

20157128

CMRR vs. Frequency at VS = 5V

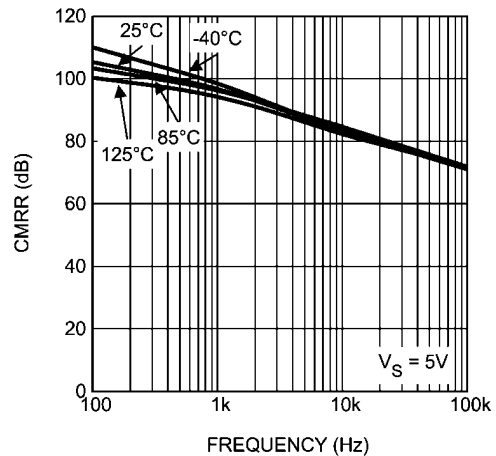

20157129

Step Response at $V_S = 3.3V$

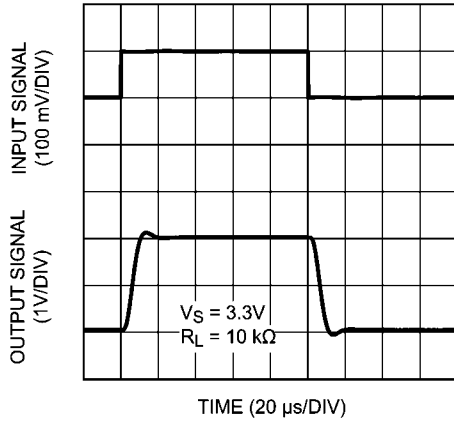

20157118

Step Response at $V_S = 5V$

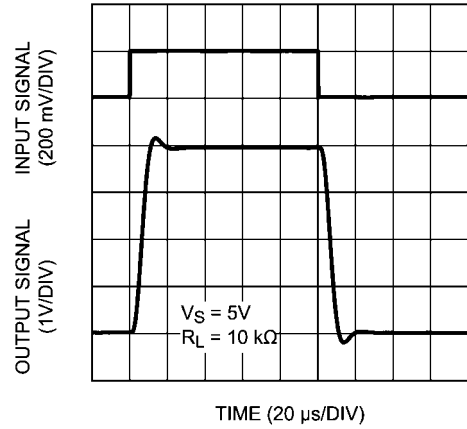

20157119

Settling Time (Falling Edge) at $V_S = 3.3V$

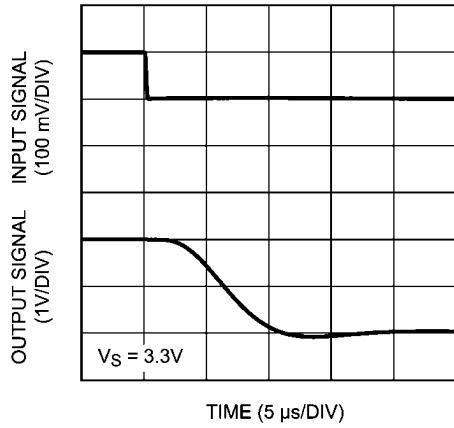

20157120

Settling Time (Falling Edge) at $V_S = 5V$

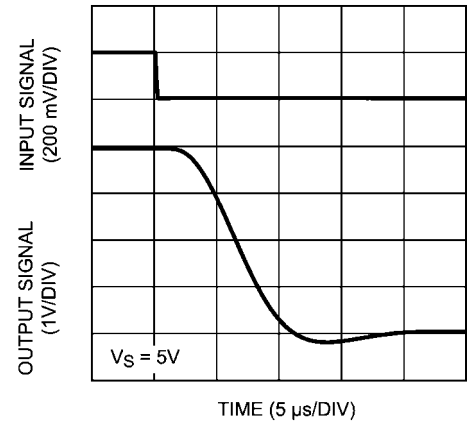

20157121

Settling Time (Rising Edge) at $V_S = 3.3V$

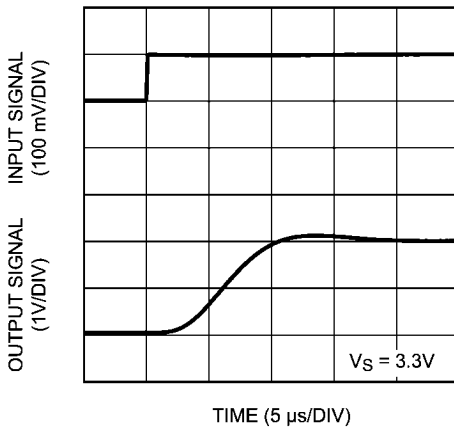

20157122

Settling Time (Rising Edge) at $V_S = 5V$

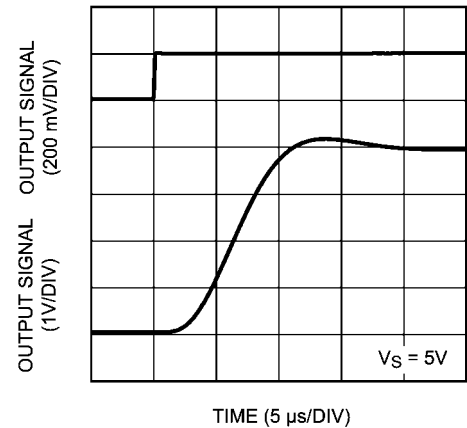

20157123

Positive Swing vs. R_{LOAD} at $V_S = 3.3V$

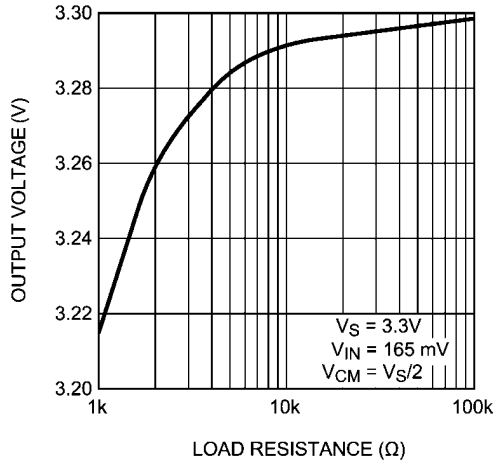

20157113

Negative Swing vs. R_{LOAD} at $V_S = 3.3V$

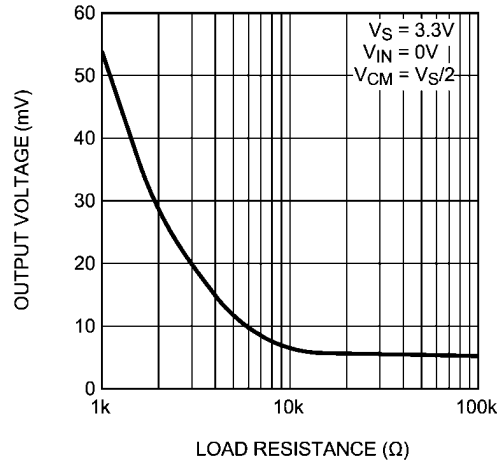

20157114

Positive Swing vs. R_{LOAD} $V_S = 5V$

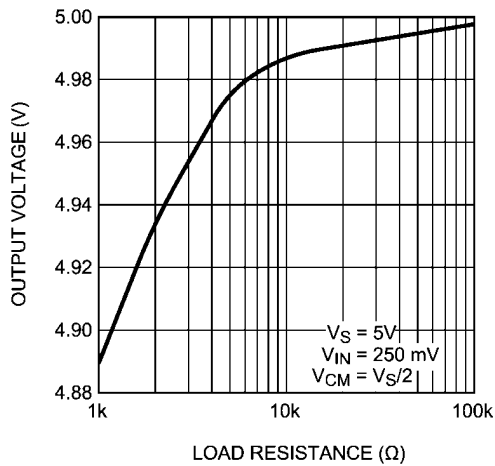

20157115

Negative Swing vs. R_{LOAD} at $V_S = 5V$

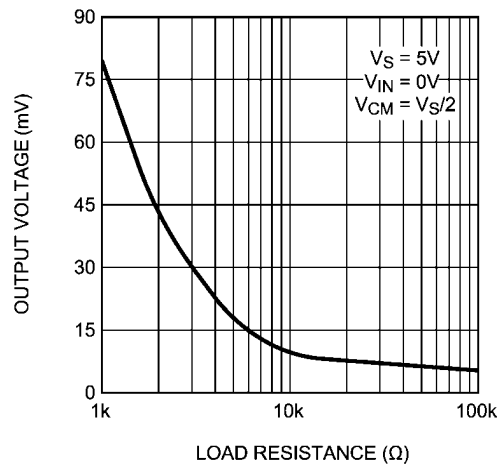

20157116

V_{OS} Distribution at $V_S = 3.3V$

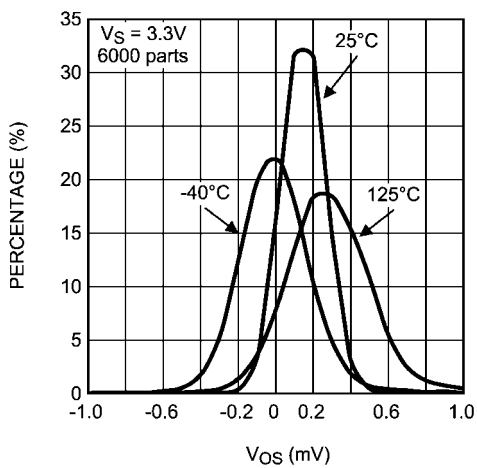

20157134

V_{OS} Distribution at $V_S = 5V$

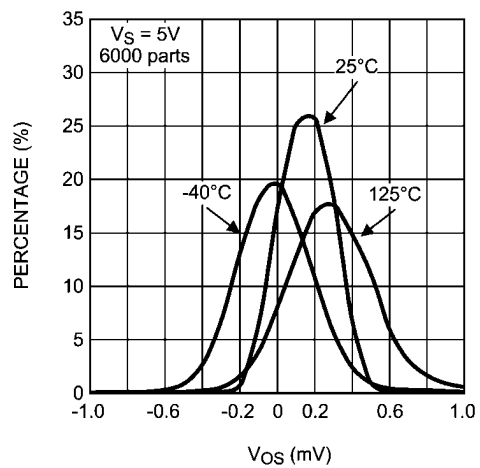

20157135

TCV_{OS} Distribution

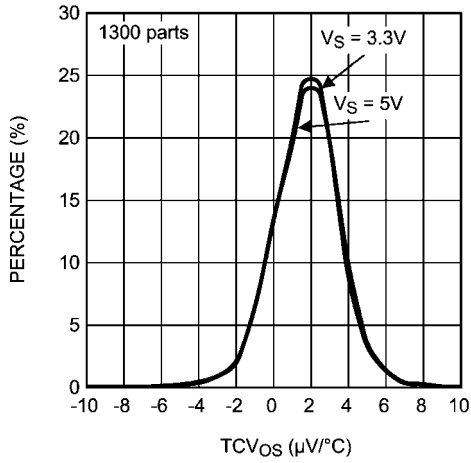

20157136

Gain Drift Distribution

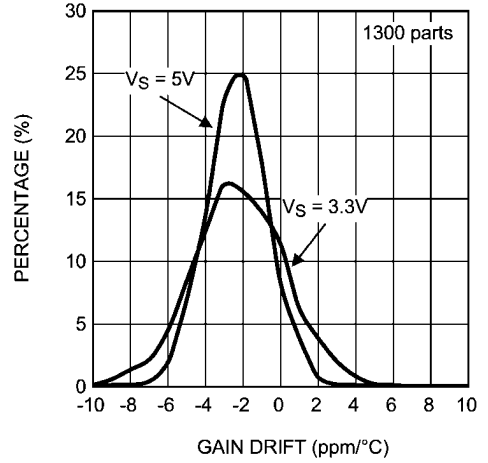

20157137

Gain error Distribution at V_S = 3.3V

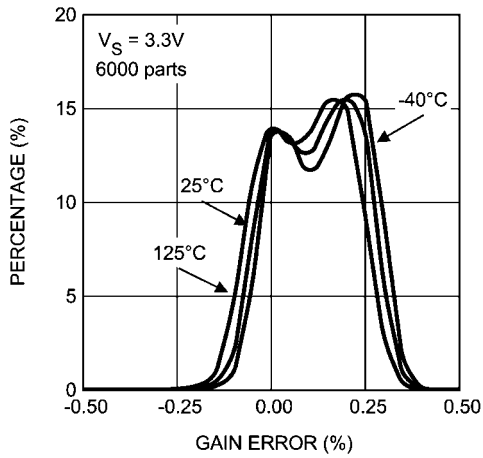

20157138

Gain error Distribution at V_S = 5V

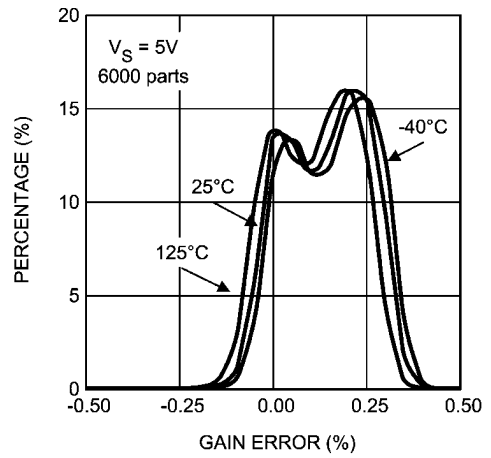

20157139

CMRR Distribution at V_S = 3.3V

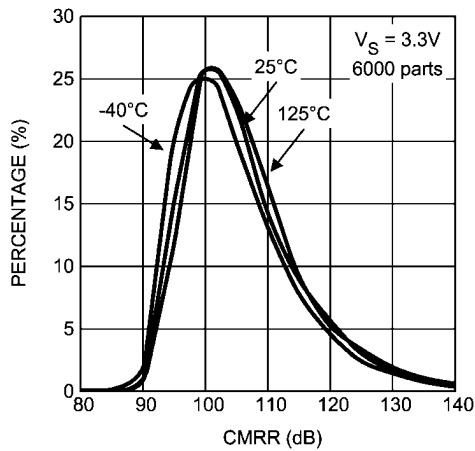

20157132

CMRR Distribution at V_S = 5V

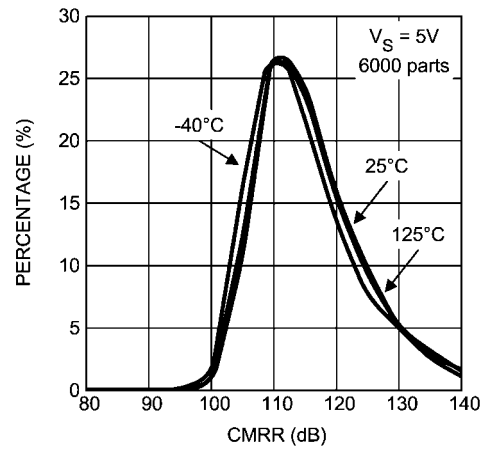

20157133

Application Information

GENERAL

The LMP8601 and LMP8601Q are fixed gain differential voltage precision amplifiers with a gain of 20x and a -22V to +60V input common mode voltage range when operating from a single 5V supply or a -4V to +27V input common mode voltage range when operating from a single 3.3V supply. The LMP8601 and LMP8601Q are members of the LMP family and are ideal parts for unidirectional and bidirectional current sensing applications. Because of the proprietary chopping level-shift input stage the LMP8601/LMP8601Q achieve very low offset, very low thermal offset drift, and very high CMRR. The LMP8601 and LMP8601Q will amplify and filter small differential signals in the presence of high common mode voltages.

The LMP8601/LMP8601Q use level shift resistors at the inputs. Because of these resistors, the LMP8601/LMP8601Q can easily withstand very large differential input voltages that may exist in fault conditions where some other less protected high-performance current sense amplifiers might sustain permanent damage.

PERFORMANCE GUARANTIES

To guaranty the high performance of the LMP8601/ LMP8601Q, all minimum and maximum values shown in the parameter tables of this data sheet are 100% tested where all bold limits are also 100% tested over temperature.

THEORY OF OPERATION

The schematic shown in *Figure 1* gives a schematic representation of the internal operation of the LMP8601/LMP8601Q.

The signal on the input pins is typically a small differential voltage across a current sensing shunt resistor. The input signal may appear at a high common mode voltage. The input signals are accessed through two input resistors. The proprietary chopping level-shift current circuit pulls or pushes current through the input resistors to bring the common mode voltage behind these resistors within the supply rails. Subsequently, the signal is gained up by a factor of 10 and brought out on the A1 pin through a trimmed 100 k Ω resistor. In the application, additional gain adjustment or filtering components can be added between the A1 and A2 pins as will be explained in subsequent sections. The signal on the A2 pin is further amplified by a factor of 2 and brought out on the OUT pin. The OFFSET pin allows the output signal to be level-shifted to enable bidirectional current sensing as will be explained below.

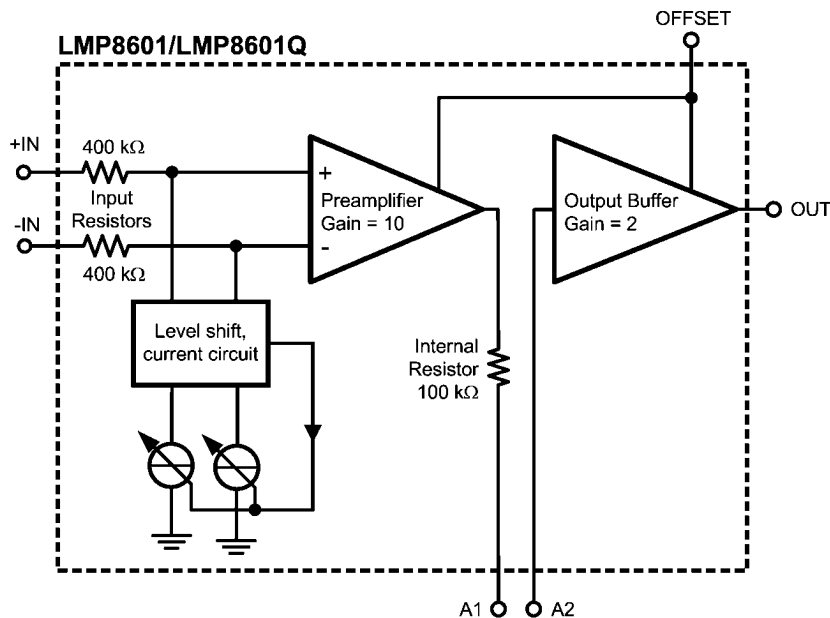

20157105

FIGURE 1. Theory of Operation

ADDITIONAL SECOND ORDER LOW PASS FILTER

The LMP8601/LMP8601Q has a third order Butterworth low-pass characteristic with a typical bandwidth of 60 kHz integrated in the preamplifier stage of the part. The bandwidth of the output buffer can be reduced by adding a capacitor on the A1 pin to create a first order low pass filter with a time constant determined by the 100 kΩ internal resistor and the external filter capacitor.

It is also possible to create an additional second order Sallen-Key low pass filter by adding external components R₂, C₁ and C₂. Together with the internal 100 kΩ resistor R₁ as illustrated in Figure 2, this circuit creates a second order low-pass filter characteristic.

When the corner frequency of the additional filter is much lower than 60 kHz, the transfer function of the described amplifier can be written as:

$$H(s) = \frac{K_1 * K_2 \frac{1}{R_1 R_2 C_1 C_2}}{s^2 + s * \left[\frac{1}{R_1 C_2} + \frac{1}{R_2 C_2} + \frac{(1 - K_2)}{R_2 C_1} \right] + \frac{1}{R_1 R_2 C_1 C_2}}$$

Where K₁ equals the gain of the preamplifier and K₂ that of the buffer amplifier.

The above equation can be written in the normalized frequency response for a 2nd order low pass filter:

$$G(j\omega) = K_1 * \frac{K_2}{\frac{(j\omega)^2}{\omega_o^2} + \frac{j\omega}{Q\omega_o} + 1}$$

The cut-off frequency ω_o in rad/sec (divide by 2π to get the cut-off frequency in Hz) is given by:

$$\omega_o = \frac{1}{\sqrt{R_1 R_2 C_1 C_2}}$$

and the quality factor of the filter is given by:

$$Q = \frac{\sqrt{R_1 R_2 C_1 C_2}}{R_1 C_1 + R_2 C_1 + (1 - K_2) * R_1 C_2}$$

With K₂ = 2x, the above equation transforms results in:

$$Q = \frac{\sqrt{R_1 R_2 C_1 C_2}}{R_1 C_1 + R_2 C_1 - R_1 C_2}$$

With this filter gain K₂= 2x, the design procedure can be very simple if the two capacitors are chosen to be equal, C₁=C₂=C. In this case, given the predetermined value of R₁ = 100kΩ (the internal resistor), the quality factor is set solely by the value of the resistor R₂.

R₂ can be calculated based on the desired value of Q as the first step of the design procedure with the following equation:

$$R_2 = \frac{R_1}{Q^2}$$

For instance, the value of Q can be set to 0.5√2 to create a Butterworth response, to 1/√3 to create a Bessel response, or a 0.5 to create a critically damped response. Once the value of R₂ has been found, the second and last step of the design procedure is to calculate the required value of C to give the desired low-pass cut-off frequency using:

$$C = \frac{Q}{R_1 \omega_o}$$

Note that the frequency response achieved using this procedure will only be accurate if the cut-off frequency of the second order filter is much smaller than the intrinsic 60 kHz low-pass filter. In other words, to have the frequency response of the LMP8601/LMP8601Q circuit chosen such that the internal poles do not affect the external second order filter.

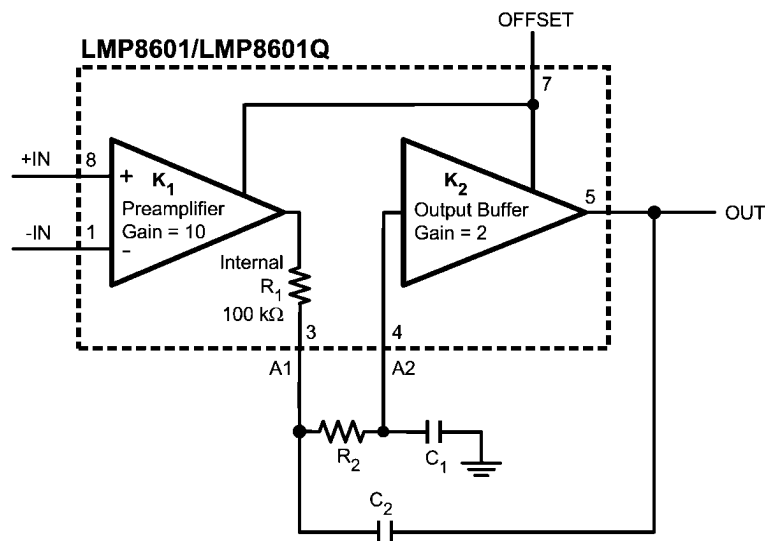

20157155

FIGURE 2. Second Order Low Pass Filter

GAIN ADJUSTMENT

The gain of the LMP8601/LMP8601Q is 20; however, this gain can be adjusted as the signal path in between the two internal amplifiers is available on the external pins.

Reduce Gain

Figure 3 shows the configuration that can be used to reduce the gain of the LMP8601/LMP8601Q.

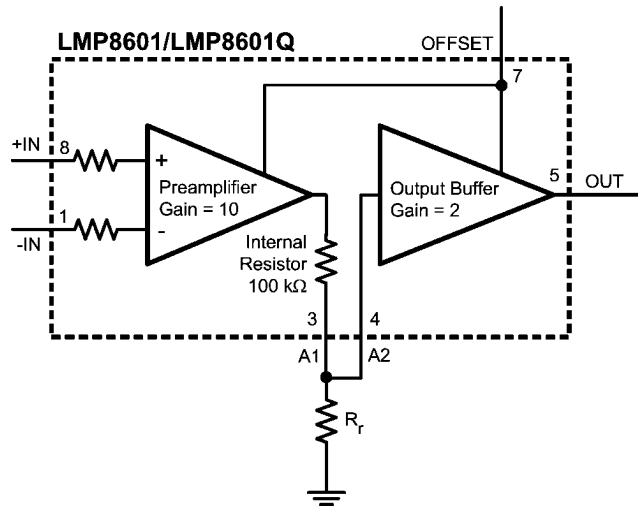

20157156

FIGURE 3. Reduce Gain

R_r creates a resistive divider together with the internal 100 kΩ resistor such that the reduced gain G_r becomes:

$$G_r = \frac{20 R_r}{R_r + 100 \text{ k}\Omega}$$

Given a desired value of the reduced gain G_r , using this equation the required value for R_r can be calculated with:

$$R_r = 100 \text{ k}\Omega \times \frac{G_r}{20 - G_r}$$

Increase Gain

Figure 4 shows the configuration that can be used to increase the gain of the LMP8601/LMP8601Q.

R_i creates positive feedback from the output pin to the input of the buffer amplifier. The positive feedback increases the gain. The increased gain G_i becomes:

$$G_i = \frac{20 R_i}{R_i - 100 \text{ k}\Omega}$$

From this equation, for a desired value of the gain, the required value of R_i can be calculated with:

$$R_i = 100 \text{ k}\Omega \times \frac{G_i}{G_i - 20}$$

It should be noted from the equation for the gain G_i that for large gains R_i approaches 100 kΩ. In this case, the denominator in the equation becomes close to zero. In practice, for large gains the denominator will be determined by tolerances in the value of the external resistor R_i and the internal 100 kΩ resistor. In this case, the gain becomes very inaccurate. If the denominator becomes equal to zero, the system will even become unstable. It is recommended to limit the application of this technique to gain values of 50 or smaller.

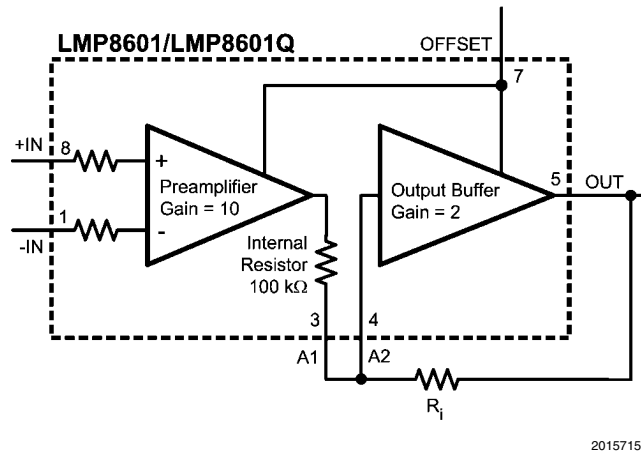

20157157

FIGURE 4. Increase Gain

BIDIRECTIONAL CURRENT SENSING

The signal on the A1 and OUT pins is ground-referenced when the OFFSET pin is connected to ground. This means that the output signal can only represent positive values of the current through the shunt resistor, so only currents flowing in one direction can be measured. When the offset pin is tied to the positive supply rail, the signal on the A1 and OUT pins is referenced to a mid-rail voltage which allows bidirectional current sensing. When the offset pin is connected to a voltage source, the output signal will be level shifted to that voltage divided by two. In principle, the output signal can be shifted to any voltage between 0 and $V_S/2$ by applying twice that voltage to the OFFSET pin.

With the offset pin connected to the supply pin (V_S) the operation of the amplifier will be fully bidirectional and symmetrical around 0V differential at the input pins. The signal at the output will follow this voltage difference multiplied by the gain and at an offset voltage at the output of half V_S .

Example:

With 5V supply and a gain of 20x, a differential input signal of +10mV will result in 2.7V at the output pin. similarly -10mV at the input will result in 2.3V at the output pin.

Note: The OFFSET pin has to be driven from a very low-impedance source ($<10\Omega$). This is because the OFFSET pin internally connects directly to the resistive feedback networks of the two gain stages. When the OFFSET pin is driven from a relatively large impedance (e.g. a resistive divider between the supply rails) accuracy will decrease.

POWER SUPPLY DECOUPLING

In order to decouple the LMP8601/LMP8601Q from AC noise on the power supply, it is recommended to use a 0.1 μF bypass capacitor between the V_S and GND pins. This capacitor should be placed as close as possible to the supply pins. In some cases an additional 10 μF bypass capacitor may further reduce the supply noise.

DRIVING SWITCHED CAPACITIVE LOADS

Some ADCs load their signal source with a sample and hold capacitor. The capacitor may be discharged prior to being connected to the signal source. If the LMP8601/LMP8601Q is driving such ADCs the sudden current that should be delivered when the sampling occurs may disturb the output signal. This effect was simulated with the circuit shown in Figure 5 where the output is to a capacitor that is driven by a rail to rail square wave.

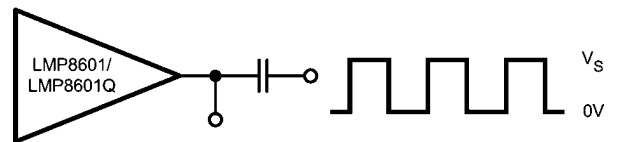

20157160

FIGURE 5. Driving Switched Capacitive Load

This circuit simulates the switched connection of a discharged capacitor to the LMP8601/LMP8601Q output. The resulting V_{OUT} disturbance signals are shown in Figure 6 and Figure 7.

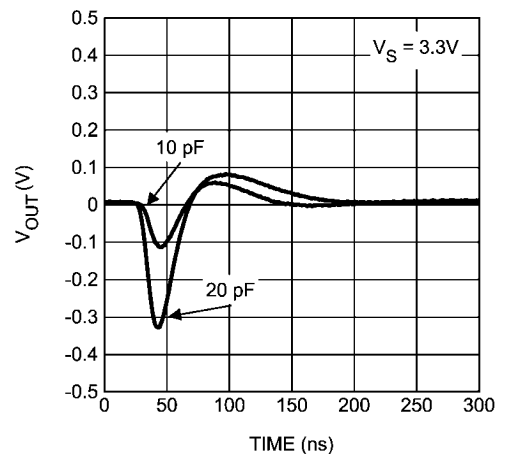

20157130

FIGURE 6. Capacitive Load Response at 3.3V

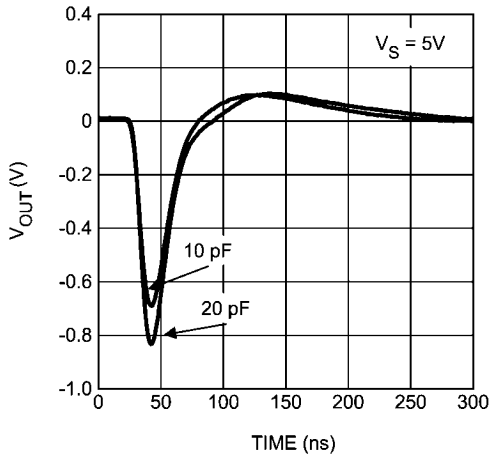

20157131

FIGURE 7. Capacitive Load Response at 5.0V

These figures can be used to estimate the disturbance that will be caused when driving a switched capacitive load. To minimize the error signal introduced by the sampling that occurs on the ADC input, an additional RC filter can be placed in between the LMP8601/LMP8601Q and the ADC as illustrated in Figure 8.

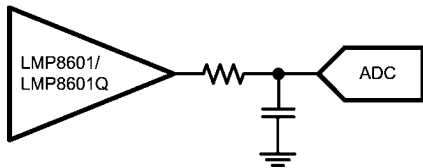

20157161

FIGURE 8. Reduce Error When Driving ADCs

The external capacitor absorbs the charge that flows when the ADC sampling capacitor is connected. The external capacitor should be much larger than the sample and hold capacitor at the input of the ADC and the RC time constant of the external filter should be such that the speed of the system is not affected.

LOW SIDE CURRENT SENSING APPLICATION

Figure 9 illustrates a low side current sensing application with a low side driver. The power transistor is pulse width modulated to control the average current flowing through the inductive load which is connected to a relatively high battery voltage. The current through the load is measured across a shunt resistor R_{SENSE} in series with the load. When the power transistor is on, current flows from the battery through the inductive load, the shunt resistor and the power transistor to ground. In this case, the common mode voltage on the shunt is close to ground. When the power transistor is off, current flows through the inductive load, through the shunt resistor and through the freewheeling diode. In this case the common mode voltage on the shunt is at least one diode voltage drop above the battery voltage. Therefore, in this application the common mode voltage on the shunt is varying between a large positive voltage and a relatively low voltage. Because the large common mode voltage range of the LMP8601/LMP8601Q and because of the high AC common mode rejection ratio, the LMP8601/LMP8601Q is very well suited for this application.

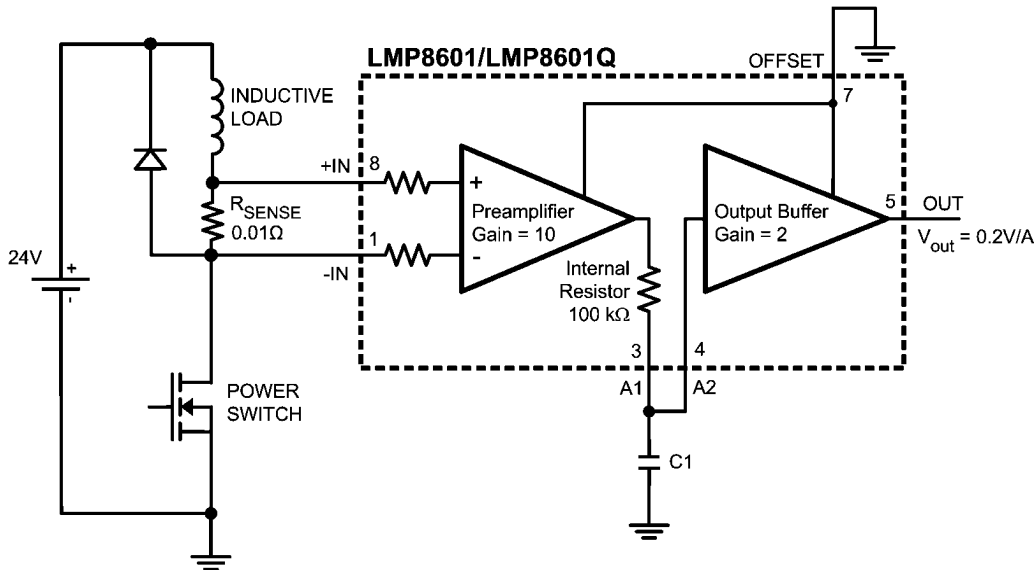

20157152

FIGURE 9. Low Side Current Sensing Application

HIGH SIDE CURRENT SENSING APPLICATION

Figure 10 illustrates the application of the LMP8601/LMP8601Q in a high side sensing application. This application is similar to the low side sensing discussed above, except in this application the common mode voltage

on the shunt drops below ground when the driver is switched off. Because the common mode voltage range of the LMP8601/LMP8601Q extends below the negative rail, the LMP8601/LMP8601Q is also very well suited for this application.

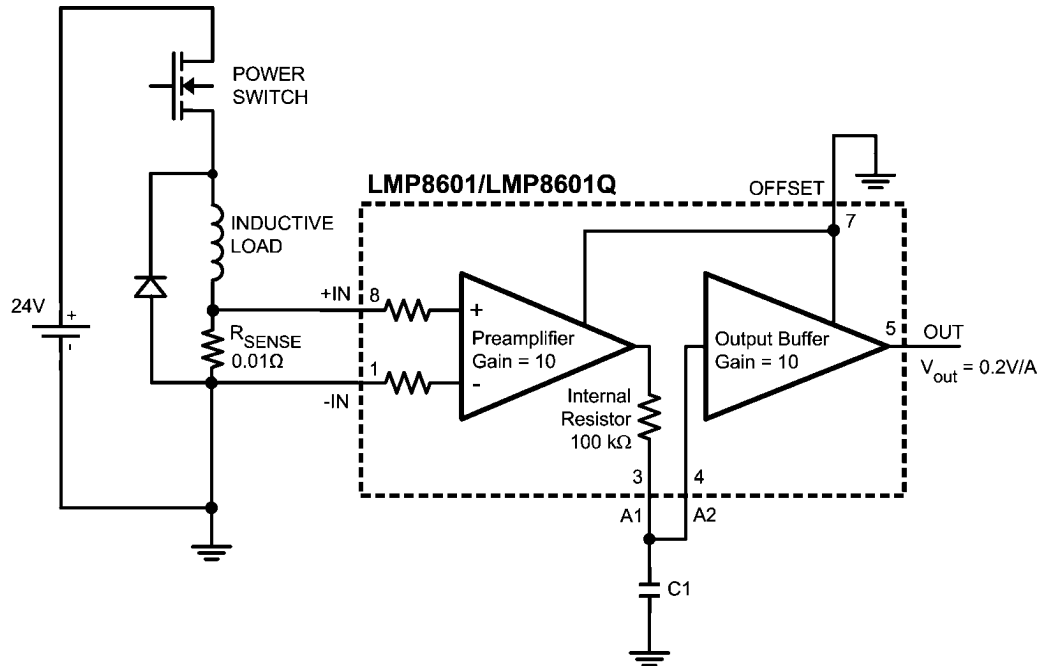

20157153

FIGURE 10. High Side Current Sensing Application

BATTERY CURRENT MONITOR APPLICATION

This application example shows how the LMP8601/LMP8601Q can be used to monitor the current flowing in and out a battery pack. The fact that the LMP8601/LMP8601Q can measure small voltages at a high offset voltage outside the parts own supply range makes this part a very good choice

for such applications. If the load current of the battery is higher than the charging current, the output voltage of the LMP8601/LMP8601Q will be above the "half offset voltage" for a net current flowing out of the battery. When the charging current is higher than the load current the output will be below this "half offset voltage".

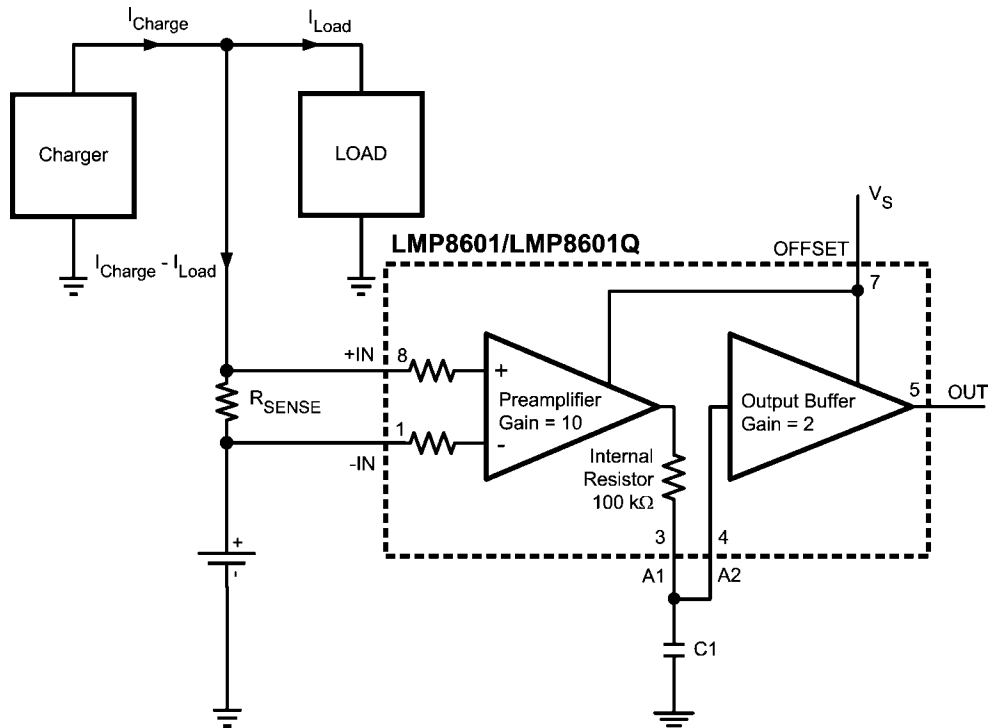

20157154

FIGURE 11. Battery Current Monitor Application

ADVANCED BATTERY CHARGER APPLICATION

The above circuit can be used to realize an advanced battery charger that has the capability to monitor the exact net current that flows in and out the battery as show in *Figure 12*. The output signal of the LMP8601/LMP8601Q is digitized with the

A/D converter and used as an input for the charge controller. The Charge controller can me used to regulate the charger circuit to deliver exactly the current that is required by the load, avoiding overcharging a fully loaded battery

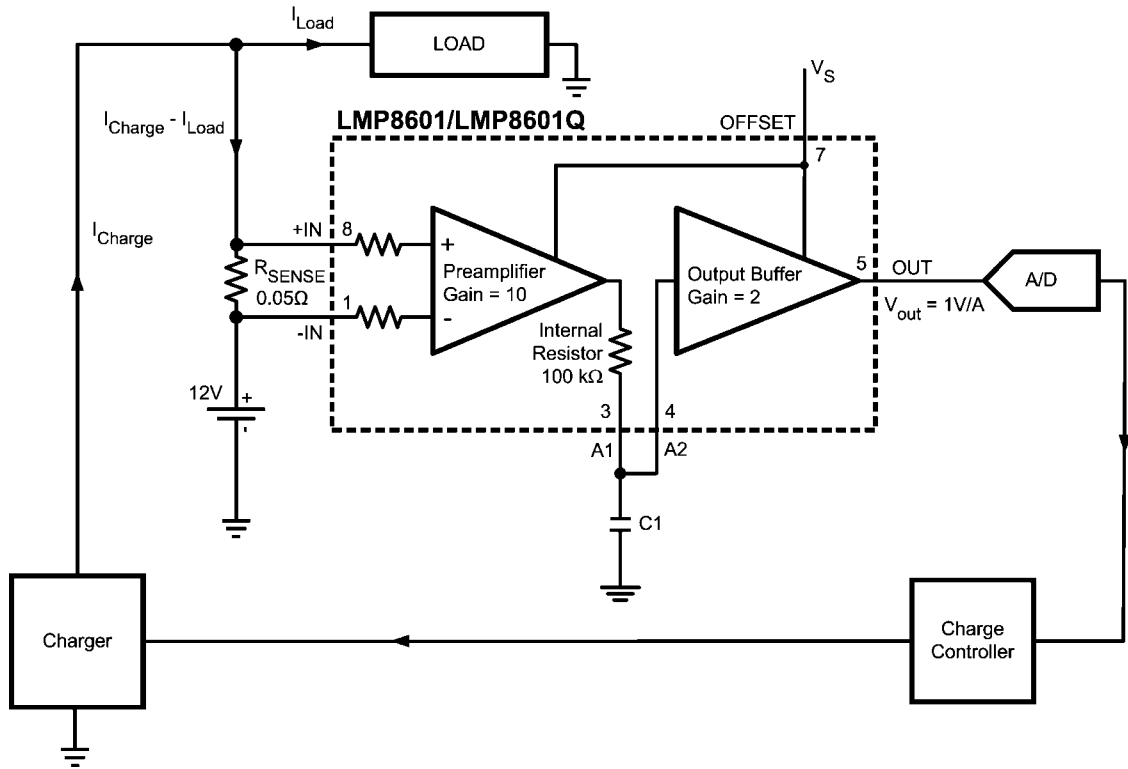

20157103

FIGURE 12. Advanced Battery Charger Application

CURRENT LOOP RECEIVER APPLICATION

Many industrial applications use 4 to 20 mA transmitters to send a sensor's analog value to a central control room. The

LMP8601/LMP8601Q can be used as a current loop receiver as shown in Figure 13.

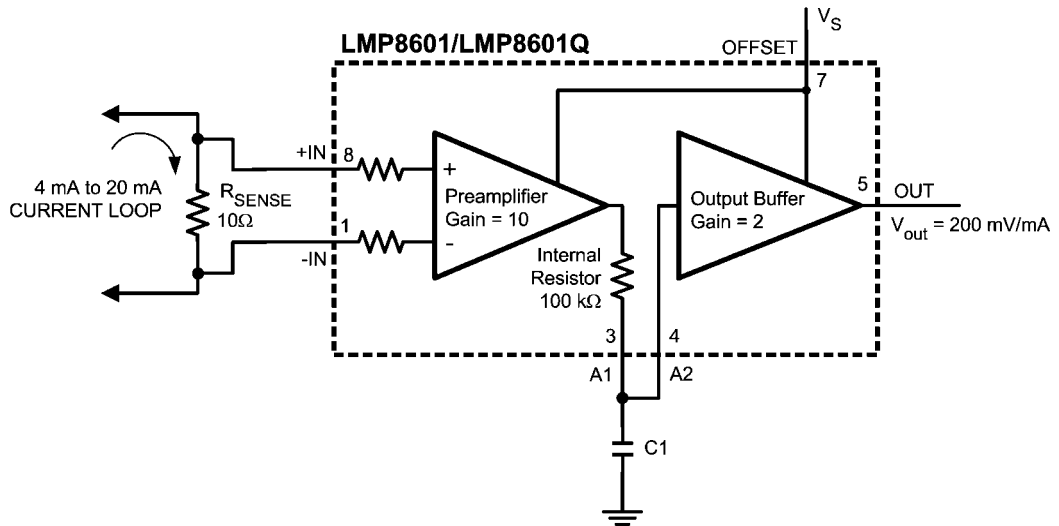

20157151

FIGURE 13.

Physical Dimensions inches (millimeters) unless otherwise noted

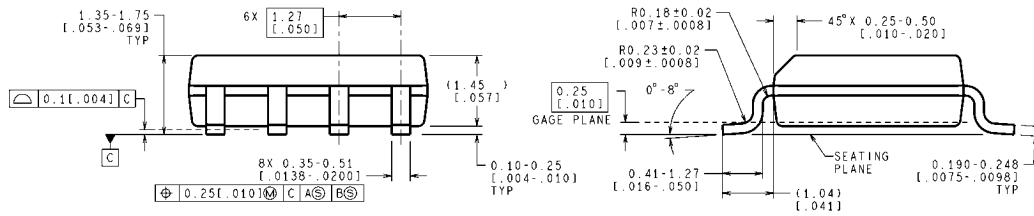
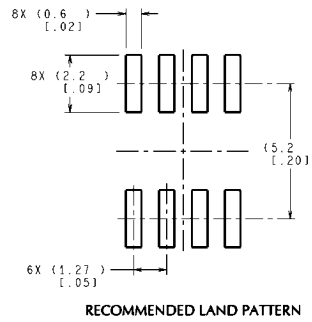
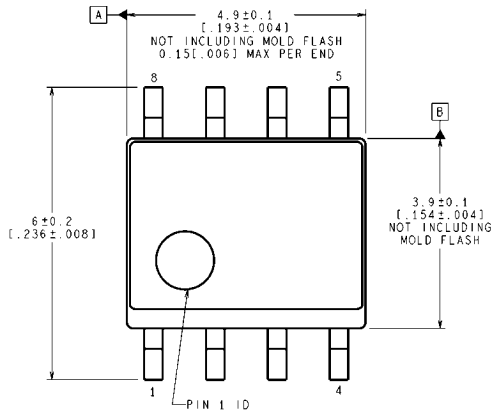

CONTROLLING DIMENSION IS MILLIMETER
VALUES IN [] ARE INCHES
DIMENSIONS IN () FOR REFERENCE ONLY

**8Pin SOIC
NS Package Number M08A**

M08A (Rev L)

Notes

For more National Semiconductor product information and proven design tools, visit the following Web sites at:

Products		Design Support	
Amplifiers	www.national.com/amplifiers	WEBENCH	www.national.com/webench
Audio	www.national.com/audio	Analog University	www.national.com/AU
Clock Conditioners	www.national.com/timing	App Notes	www.national.com/appnotes
Data Converters	www.national.com/adc	Distributors	www.national.com/contacts
Displays	www.national.com/displays	Green Compliance	www.national.com/quality/green
Ethernet	www.national.com/ethernet	Packaging	www.national.com/packaging
Interface	www.national.com/interface	Quality and Reliability	www.national.com/quality
LVDS	www.national.com/lvds	Reference Designs	www.national.com/refdesigns
Power Management	www.national.com/power	Feedback	www.national.com/feedback
Switching Regulators	www.national.com/switchers		
LDOs	www.national.com/lido		
LED Lighting	www.national.com/led		
PowerWise	www.national.com/powerwise		
Serial Digital Interface (SDI)	www.national.com/sdi		
Temperature Sensors	www.national.com/tempsensors		
Wireless (PLL/VCO)	www.national.com/wireless		

THE CONTENTS OF THIS DOCUMENT ARE PROVIDED IN CONNECTION WITH NATIONAL SEMICONDUCTOR CORPORATION ("NATIONAL") PRODUCTS. NATIONAL MAKES NO REPRESENTATIONS OR WARRANTIES WITH RESPECT TO THE ACCURACY OR COMPLETENESS OF THE CONTENTS OF THIS PUBLICATION AND RESERVES THE RIGHT TO MAKE CHANGES TO SPECIFICATIONS AND PRODUCT DESCRIPTIONS AT ANY TIME WITHOUT NOTICE. NO LICENSE, WHETHER EXPRESS, IMPLIED, ARISING BY ESTOPPEL OR OTHERWISE, TO ANY INTELLECTUAL PROPERTY RIGHTS IS GRANTED BY THIS DOCUMENT.

TESTING AND OTHER QUALITY CONTROLS ARE USED TO THE EXTENT NATIONAL DEEMS NECESSARY TO SUPPORT NATIONAL'S PRODUCT WARRANTY. EXCEPT WHERE MANDATED BY GOVERNMENT REQUIREMENTS, TESTING OF ALL PARAMETERS OF EACH PRODUCT IS NOT NECESSARILY PERFORMED. NATIONAL ASSUMES NO LIABILITY FOR APPLICATIONS ASSISTANCE OR BUYER PRODUCT DESIGN. BUYERS ARE RESPONSIBLE FOR THEIR PRODUCTS AND APPLICATIONS USING NATIONAL COMPONENTS. PRIOR TO USING OR DISTRIBUTING ANY PRODUCTS THAT INCLUDE NATIONAL COMPONENTS, BUYERS SHOULD PROVIDE ADEQUATE DESIGN, TESTING AND OPERATING SAFEGUARDS.

EXCEPT AS PROVIDED IN NATIONAL'S TERMS AND CONDITIONS OF SALE FOR SUCH PRODUCTS, NATIONAL ASSUMES NO LIABILITY WHATSOEVER, AND NATIONAL DISCLAIMS ANY EXPRESS OR IMPLIED WARRANTY RELATING TO THE SALE AND/OR USE OF NATIONAL PRODUCTS INCLUDING LIABILITY OR WARRANTIES RELATING TO FITNESS FOR A PARTICULAR PURPOSE, MERCHANTABILITY, OR INFRINGEMENT OF ANY PATENT, COPYRIGHT OR OTHER INTELLECTUAL PROPERTY RIGHT.

LIFE SUPPORT POLICY

NATIONAL'S PRODUCTS ARE NOT AUTHORIZED FOR USE AS CRITICAL COMPONENTS IN LIFE SUPPORT DEVICES OR SYSTEMS WITHOUT THE EXPRESS PRIOR WRITTEN APPROVAL OF THE CHIEF EXECUTIVE OFFICER AND GENERAL COUNSEL OF NATIONAL SEMICONDUCTOR CORPORATION. As used herein:

Life support devices or systems are devices which (a) are intended for surgical implant into the body, or (b) support or sustain life and whose failure to perform when properly used in accordance with instructions for use provided in the labeling can be reasonably expected to result in a significant injury to the user. A critical component is any component in a life support device or system whose failure to perform can be reasonably expected to cause the failure of the life support device or system or to affect its safety or effectiveness.

National Semiconductor and the National Semiconductor logo are registered trademarks of National Semiconductor Corporation. All other brand or product names may be trademarks or registered trademarks of their respective holders.

Copyright© 2008 National Semiconductor Corporation

For the most current product information visit us at www.national.com



**National Semiconductor
Americas Technical
Support Center**
Email: support@nsc.com
Tel: 1-800-272-9959

**National Semiconductor Europe
Technical Support Center**
Email: europe.support@nsc.com
German Tel: +49 (0) 180 5010 771
English Tel: +44 (0) 870 850 4288

**National Semiconductor Asia
Pacific Technical Support Center**
Email: ap.support@nsc.com

**National Semiconductor Japan
Technical Support Center**
Email: jpn.feedback@nsc.com